



International Association of Operative Millers 2008

**Tanzania, Arusha
14-17 November 2008**

R.Bontemps

F08/2953 ₁



Agricultural products: packaging



Open mouth bags



New products



New products



Sewing technique: plain sewn top

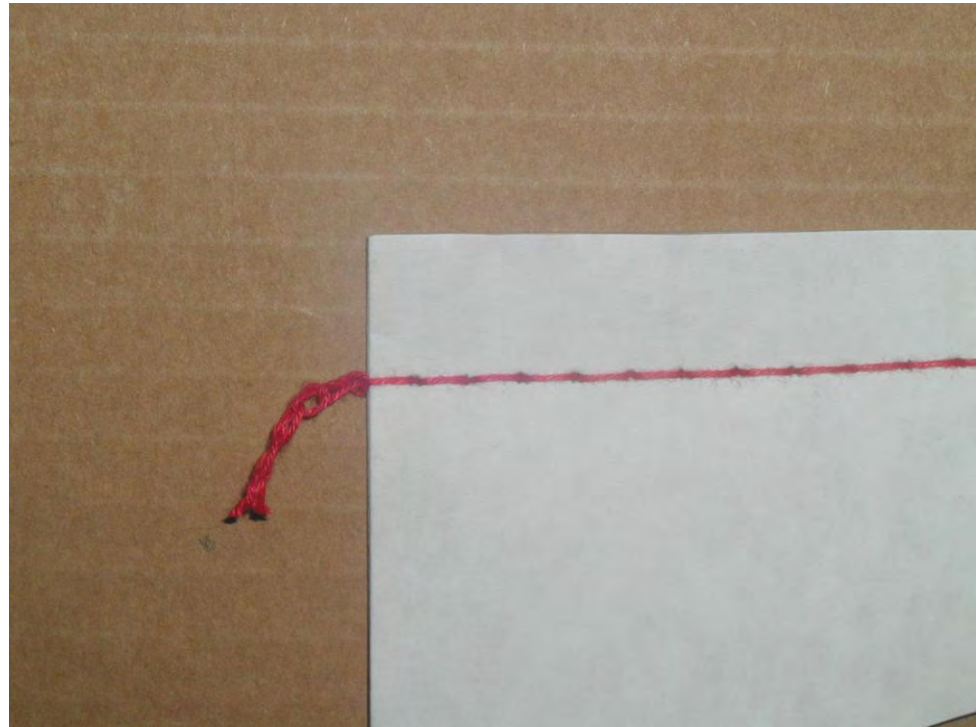
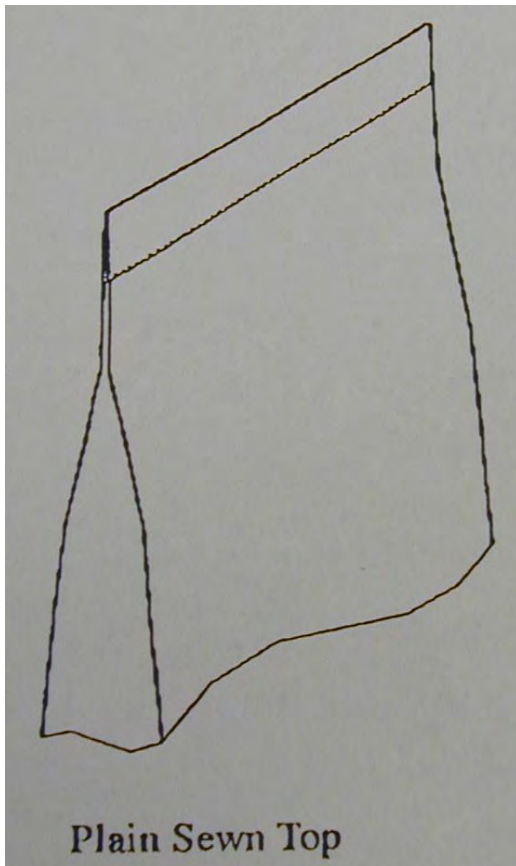

Sewing Technique : Sewing with crepe paper



Sewing: solution for closing open mouth bags



Sewing technique: easy open tape

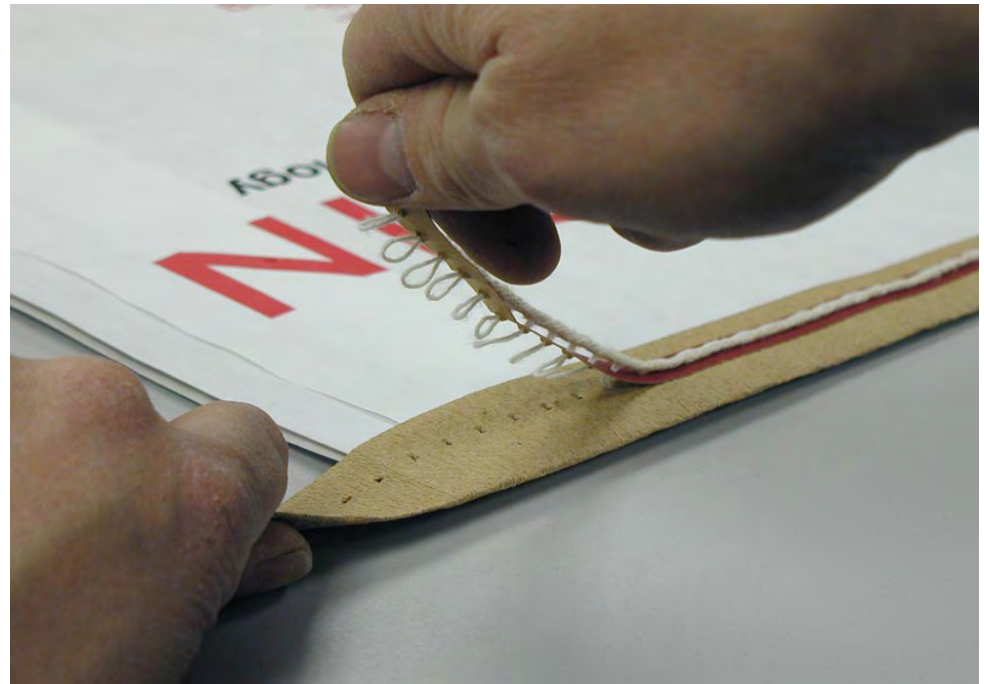
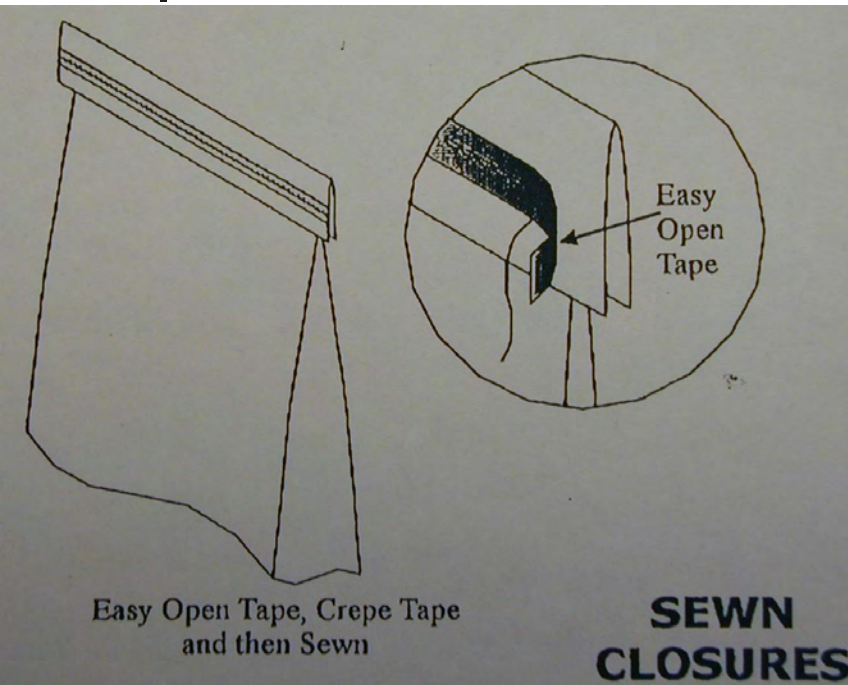
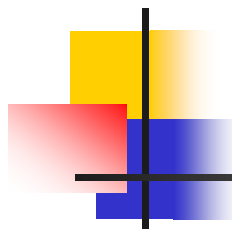

Sewing technique: tape over sew



Sewing technique: twin closure New!



Sewing technique: twin closure NEW!!

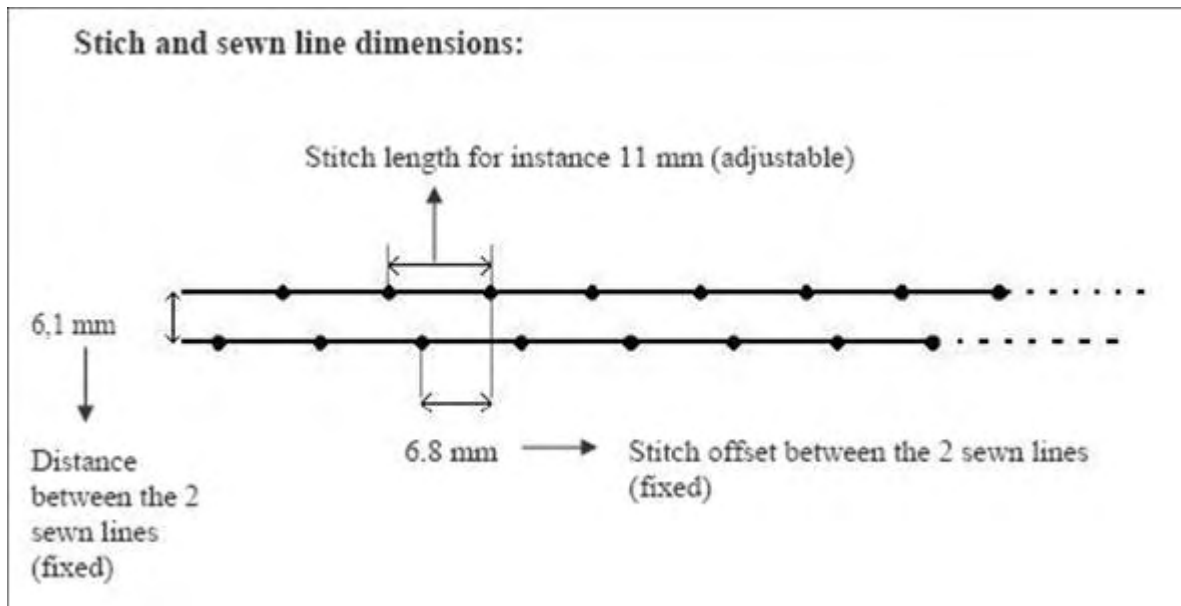

Twin needle Sewing Head: New!

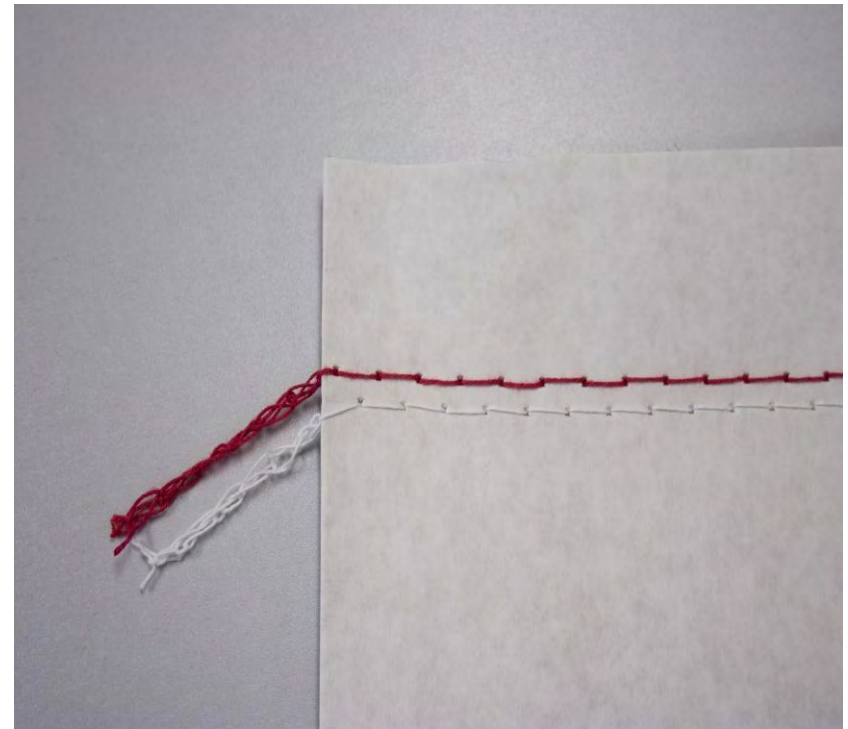

High speed sewing systems :New!



Sealing technique



Sealing technique: conduction

Band sealers

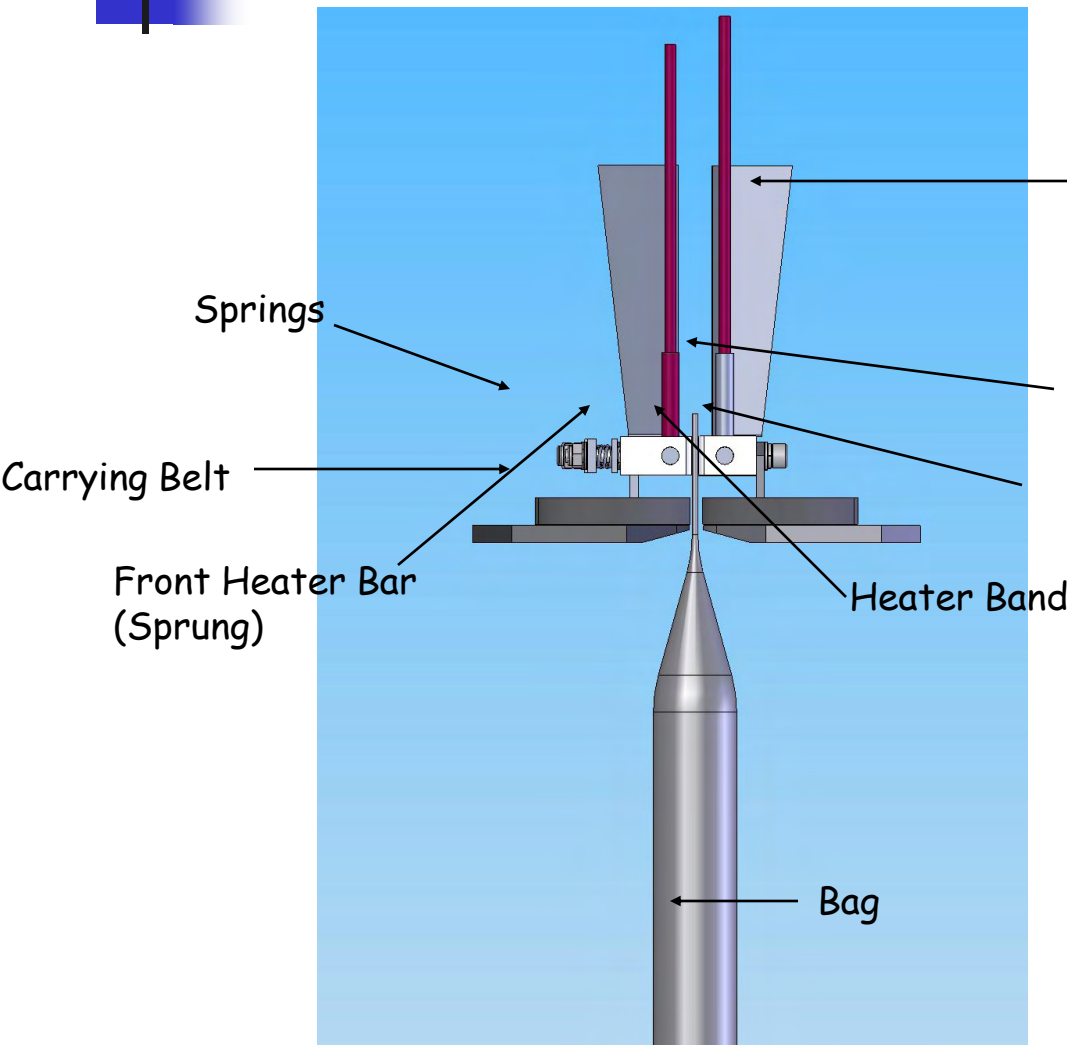

Cooling Air Duct

Heater Element

Rear Heater Bar (Fixed)

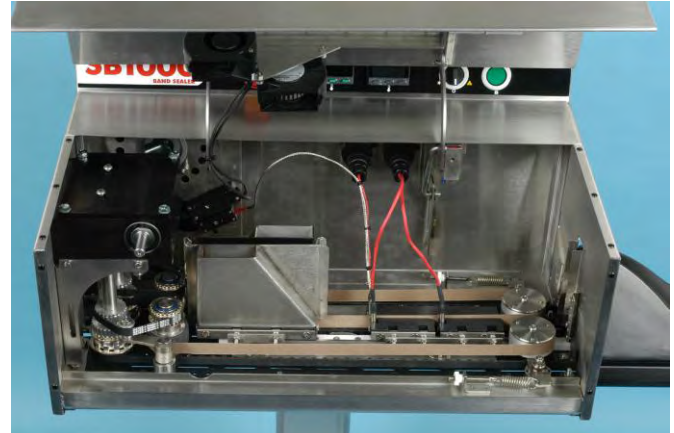

Saxon Band sealer SB4000: NEW!



SB4000-special features

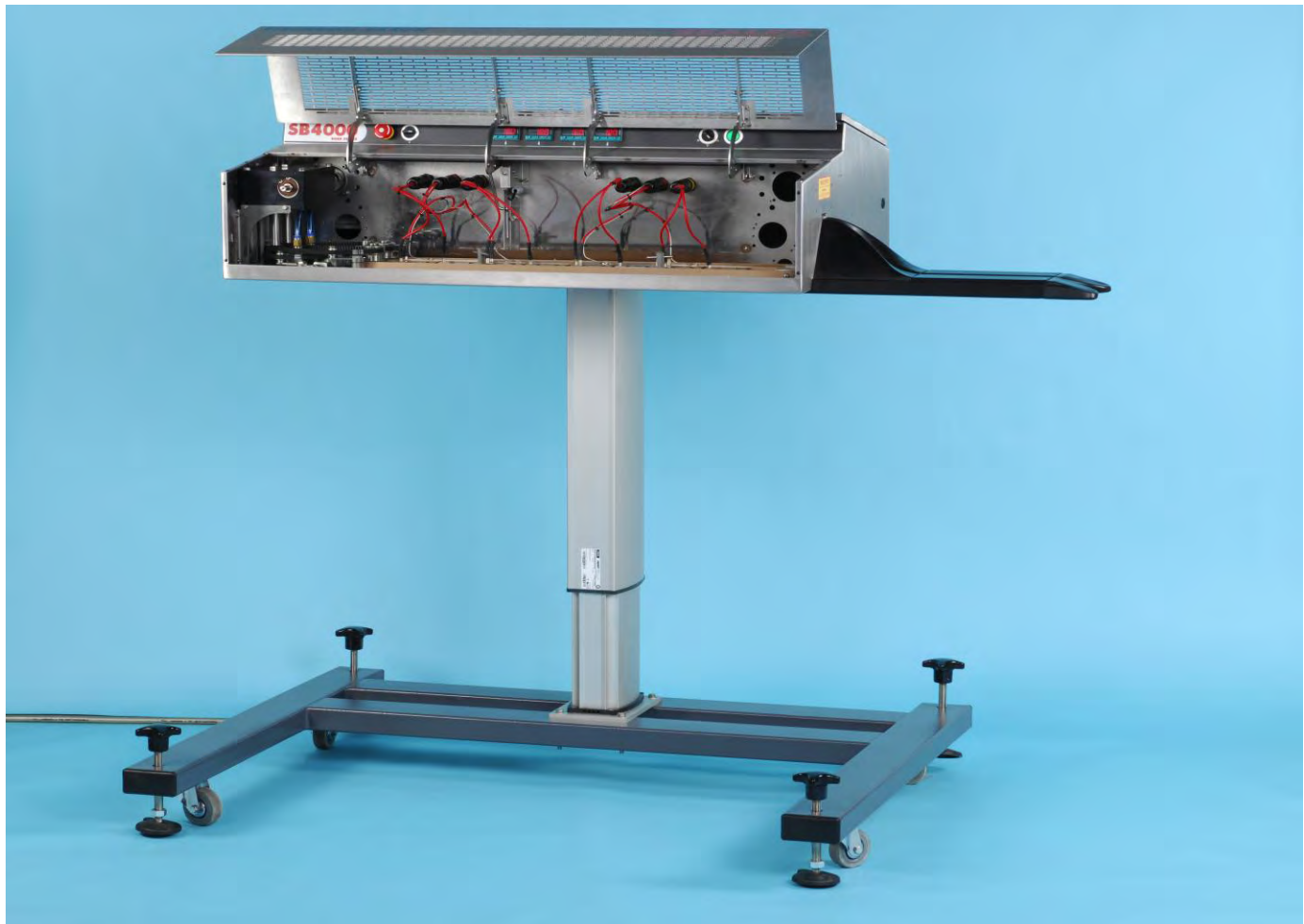



Saxon Band sealer SB4000

- New mainframe with simplified design
- Stainless steel
- VFD speed control with speed up to 14m/min (more with options)
- Electric column



Fischbein

- **SOLUTIONS**

- to your specific bag closing requirements from an extensive range of quality equipment .

- **DEVELOPMENT**

- using the latest proven technology to continue leading the field

- **WORLDWIDE SERVICE**

- through a large distributors network.

- **« JUST IN TIME » DELIVERIES**

- equipment and spare parts available from stocks to ensure continuous

- production.

- **QUALITY PRODUCTS**